

Technical paper

Hydraulic balance in a district heating system

Herman Boysen, Product Application Manager, Danfoss A/S

Jan Eric Thorsen, Application Centre Manager, Danfoss A/S

Published in EuroHeat & Power IV/2007

(www.vwew.de)

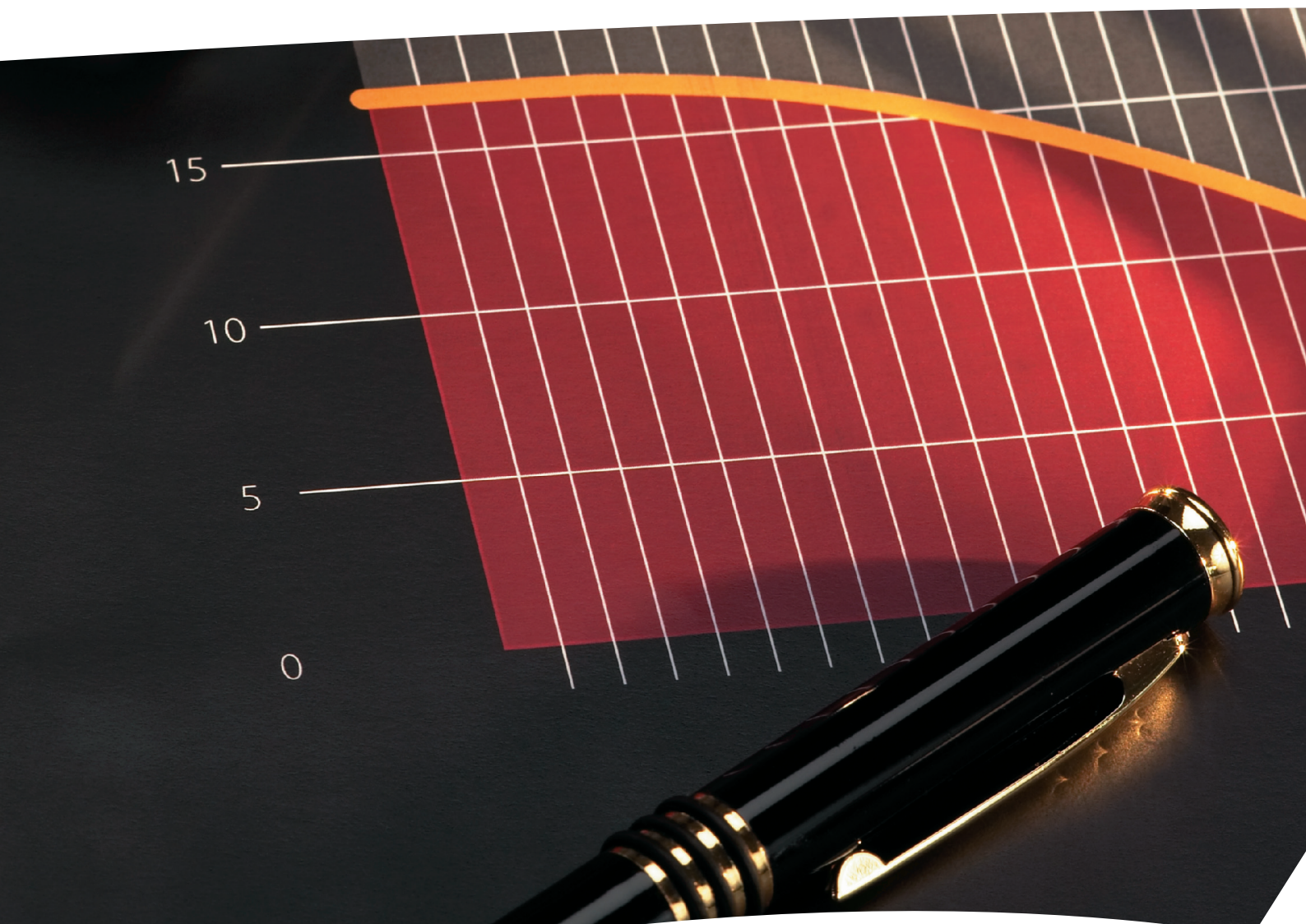

TECHNICAL PAPER

Hydraulic balance in a district heating system

Establishing a hydraulic balance in a system often is a matter of controlling the differential pressure to a level necessary for operating the substation and thereby also controlling the flow rate in individual branches. Controlling differential pressure and flow rate in the system can have advantages for customers and utilities. This will in the future bring hydraulic balance in district heating systems into focus in the continuous effort to reduce the operating costs.

Author(s)



Herman Boysen, Product Application Manager, Danfoss A/S
Danfoss District Energy, Nordborg, Denmark,
+45 7488 4494 · boy@Danfoss.com

Jan Eric Thorsen, Application Specialist, Danfoss A/S
Danfoss District Energy, Nordborg, Denmark,
+45 7488 4494 · jet@Danfoss.com

The precondition for a well functioning district heating system with a high temperature difference ΔT between supply and return pipeline and a low flow rate is that the water flow in the entire system is well balanced. This means: A hydraulic balance in the system has to be established. The system can be split-up in three categories which can be balanced individually. These are (figure 1):

- distribution networks,
- central heating system (house substations),
- house heating systems.

Type of systems in a distribution system can be

- constant flow systems (not often used),
- variable flow systems.

In the central heating system the substation type can be

- a directly connected systems with and without mixing loop,
- an indirectly connected systems with heat exchangers.

The house heating systems can be

- a one pipe systems (not often used in modern district heating systems),
- a two pipe systems.

However, the house heating system normally is not part of the district heating system. A hydraulic balance in this part of the entire system is very important in order to keep a low return temperature in the district heating network. However, methods to establish a hydraulic balance in this part of the system is not subject of this article.

Hydraulic Balance in the Supply Network

A district heating network is in hydraulic balance when the water flow to the individual consumers is exactly what they need to fulfil the demand for heating in the house. According to the specification, hydraulic balance means limitation of the flow range in a system to a flow rate corresponding to real consumption. Results of an incorrect hydraulic balance are:

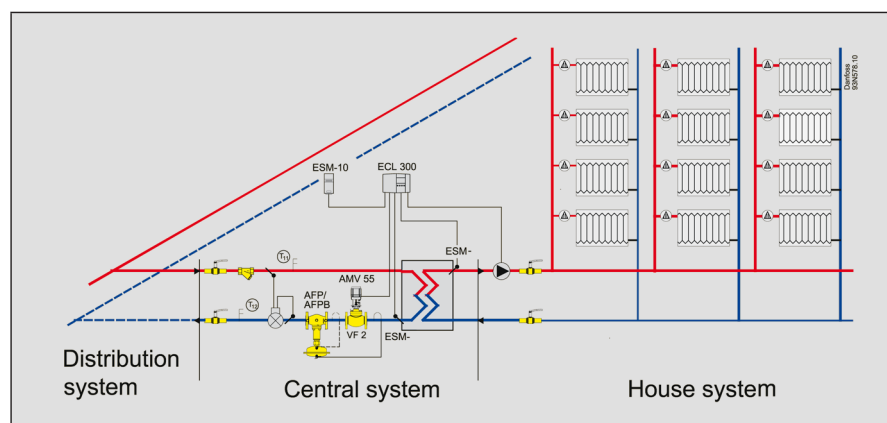

FIGURE 1: A district heating system split up in 3 main groups

- a low ΔT in the supply system,
- a high flow rate,
- high heat losses in the pipe network
- high pumping costs which means waste of energy.

Establishing a hydraulic balance in a distribution system is a matter of adapting the water flow in the system to the maximum real needed consumption in the entire system.

Reasons for Incorrect Hydraulic Balanced Systems

If a system is not in hydraulic balance, the reasons could be:

- the control valves are oversized,
- the consumption is not according to specification,
- no devices exist to adjust the flow range,
- incorrect control equipment,
- oversized or incorrectly adjusted pumps,
- commissioning has not been carried out.

Equipment for establishing a hydraulic balance in a system can be (figure 2):

- manual balancing valves,
- differential pressure controllers,
- flow controllers,
- combined differential pressure controller and with flow limitation,
- combined differential pressure controller and with flow control,
- pump control (not mentioned in this article).

Where to be used

Manual balancing valves are mostly used in small heating loops with minor variation in differential pressure.

Differential pressure controllers are often used in systems with high differential pressure and variations in the differential pressure. The system can be set up according to the necessary differential pressure in the substation.

A flow controller will be a good solution in systems where the delivered capacities in the individual branches are known. It is also very often used as basis for the allocated flow rate in a tariff system.

The selection of differential pressure control, flow limitation or flow control in a system depends on:



FIGURE 2: Differential pressure controllers, flow limiters and flow controllers, which can be used in central systems and district heating systems to maintain a hydraulic balance

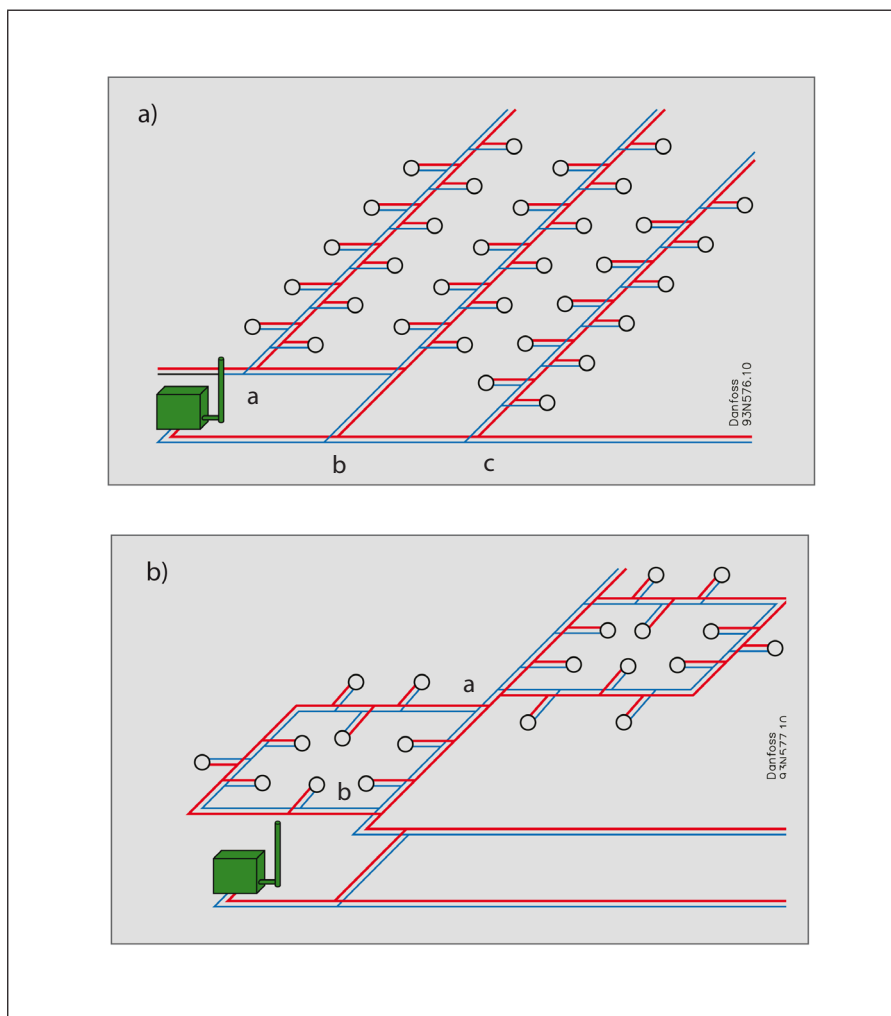

FIGURE 3: Lined (a) and meshed (b) network systems

- type of system,
- size of system,
- knowledge of flow rate in the system,
- tariff systems.

Distribution System

Roughly, the district heating distribution system can be split-up in two categories – in a lined network systems and in a meshed network systems (figure 3).

Lined Network System

A lined network system has one supply line to the individual consumer groups. The flow rate in the pipe net therefore depends on the individual consumption.

Under precondition that max. flow rates for the individual consumers are well documented, a flow controlling of the individual group branches a, b and c can be done. This is not so often seen.

Meshed Network System

In a meshed network a group of consumers can be supplied from two sides a and b. The flow rate in the individual supply lines a and b to the group depends on the consumption of the individual consumers in the mesh and the location of them.

This type of network is often used.

Flow control and differential control of the individual meshes is not possible because they have double supply lines and variable flow rate depending of the consumption in the mesh.

Constant Flow System and variable flow system

Furthermore, the distribution system can be split-up in the categories constant flow systems (figure 4) and variable flow systems (figure 5). Both systems have advantages and disadvantages.

Constant Flow System

The advantage of a constant flow system is the high rate of hydraulic balance. The disadvantages are the high return temperature, high heat losses in the network and high pump costs.

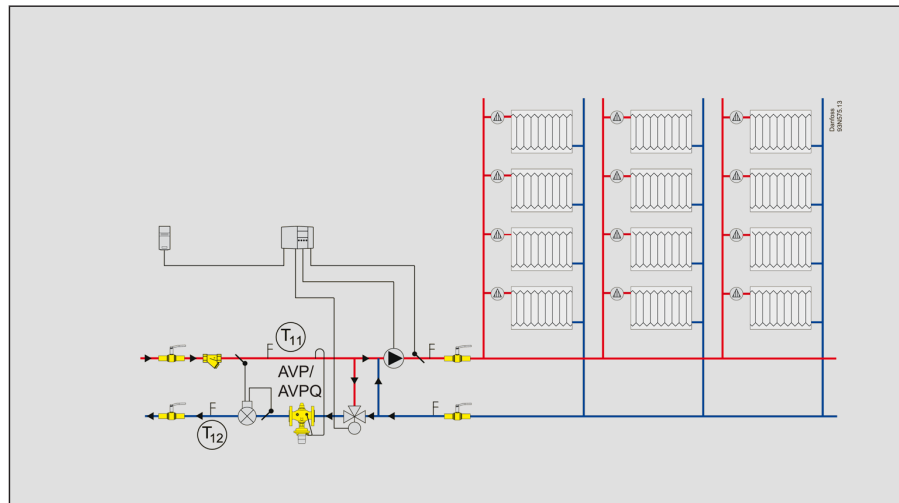

FIGURE 4: Constant flow system

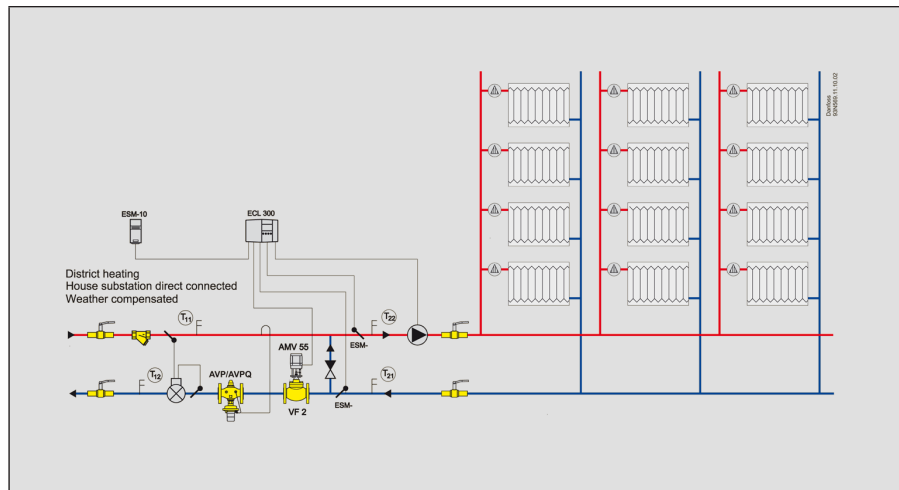

FIGURE 5: Variable flow system

Flow and Pressure Control in a Constant Flow System

In a distribution system where the flow rate in all substations is well adjusted, a hydraulic balance is just a matter of sufficient pump pressure.

Differential pressure controllers and manual balancing valves can be used to limit the flow rate in this type of system. In systems with variations of the differential pressure, differential pressure controllers or combined controllers are to be preferred.

Variable Flow System

The advantages of a variable flow system are the low return temperature and the low heat losses in the network. The disadvantage is the risk of insufficient hydraulic balance.

If a hydraulic balance can be established in a variable flow system, this system is to be preferred as a district heating supply network.

In this article information will be given on how to establish hydraulic balance in a variable flow system.

As before mentioned, the establishment of a hydraulic balance in the network branches by means of differential pressure controllers and flow controllers are not often applied.

However, differential pressure controllers are often used in the network to avoid high differential pressure in a branch and also to establish sufficient high total pressure on high elevations in the supply areas. The hydraulic balance therefore has to be carried out at the central system.

Central System (Substation)

Typical application types in central heating systems with variable flow are

- directly connected systems with and without mixing loops,
- indirectly connected system.

Pressure and flow controllers in central systems to maintain a hydraulic balance, could be:

- flow controller,
- differential pressure controller,
- differential pressure controller with flow limitation,
- differential pressure controller with flow control,
- combined temperature controller and differential pressure controller.

Flow Controller

A flow controller has a diaphragm element with a restrictor integrated on top of the valve.

The flow controller keeps a constant differential pressure across a built-in restrictor and thereby controls the flow rate in the system (figure 6).

A flow controller has no integrated differential pressure function for the system.

Typical applications for flow controllers are:

- systems where pressure variations Δp are very low,
- one pipe systems as riser controller.

Differential Pressure Controller

A differential pressure controller consists of a control valve and a diaphragm element. Differential pressure controllers are mainly used to keep a constant differential pressure across a motorized control valve or a total system:

$$Q = k_v \cdot \sqrt{\Delta p_v} \text{ in } \frac{\text{m}^3}{\text{h}}$$

with

Q: controlled flow in m^3/h ,

k_v : capacity of the the part of the system within the connection point of the impulse tubes in m^3/h ,

Δp_v : controlled Δp across the part of the system within the connection point of the impulse tubes in bar.

A differential pressure controller can operate as a flow limiter in combination with a motorized control valve (figure 7). However, they are not often used for this purpose.

Combination Valve

In systems with a limited capacity or where the tariff is based on the allocated capacity, a type of flow limitation or flow control in combination with a differential pressure controller can be preferred. There are two main functions to be used:

- combined differential pressure controller with flow limitation,
- combined differential pressure controller with flow controlling.

Combined Differential Pressure Controlling with Flow Limitation

A combined differential pressure controller and flow limiter consists of a differential pressure controller with an integrated restrictor on top of the valve. As the flow limitation in this controller is based on all restrictions, within the connecting points where the impulse tube are connected, this type of flow limiter is often used in loops where the differential pressure across all equipment in the loop is well defined.

The controller maintains a constant Δp across the resistance valve and the motorized control valve. The flow limitation is based on the size of the valve and the setting of the internal throttle valve in the flow limiter.

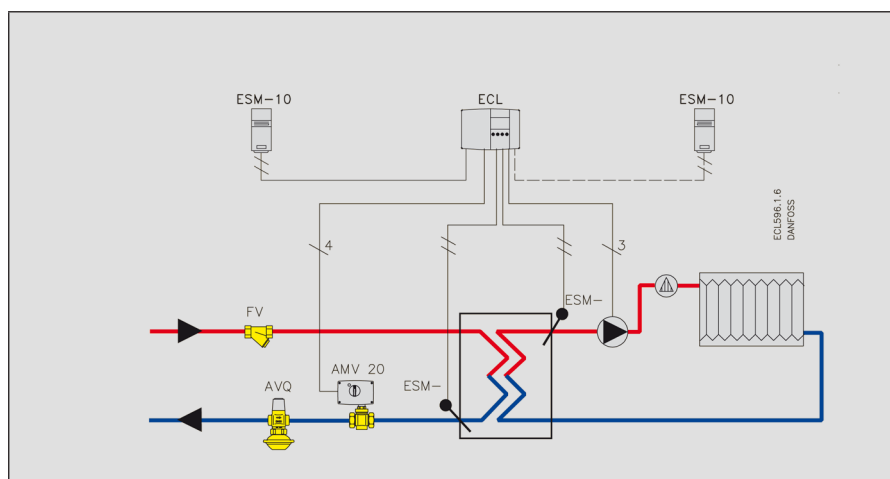

FIGURE 6: Heating loop with a flow controller

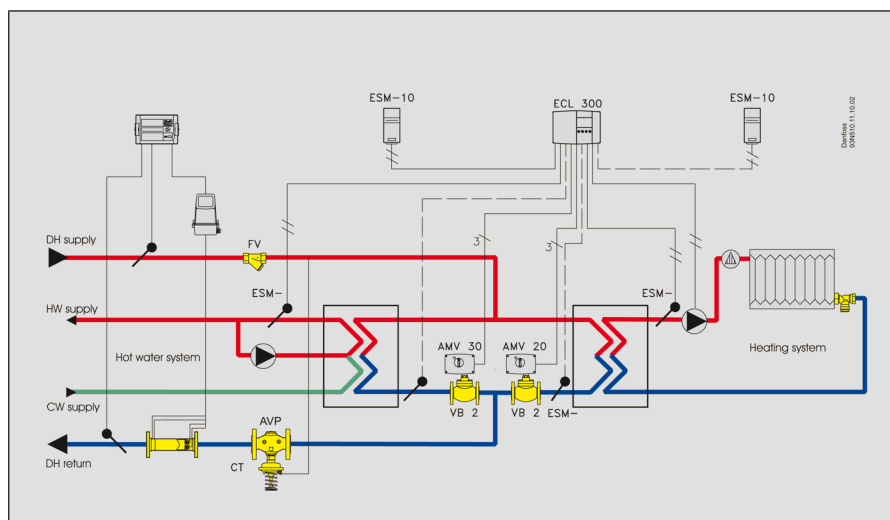

FIGURE 7: Differential pressure controlling of a parallel connected district heating substation

The flow rate Q_{Total} of serial connected valves, restrictor and motorized control valve, is calculated as:

$$Q_{\text{Total}} = k_{v\text{Total}} \cdot \sqrt{\Delta p_{v\text{Total}}} \text{ in } \frac{\text{m}^3}{\text{h}}$$

$$Q_{\text{Total}} = \frac{k_{v1} \cdot k_{v2}}{\sqrt{k_{v1} + k_{v2}}} \cdot \sqrt{\Delta p_{v1} + \Delta p_{v2}}$$

If the built-in restriction valve k_{v1} in the flow limiter has the majority, a change in capacity of the motorized control valve k_{v2} does not influence the total capacity considerable. On the other hand, the higher the resistance in the restrictor valve, the lower the valve authority will be on the motorized control valve (figure 10).

Applications for Flow Limitation

Flow controlling with a flow limiter is based on the resistance within the connecting points for the impulse tubes.

Flow limitation is often used for establishing hydraulic balance in indirectly connected systems with one or two motorized control valves in parallel (figure 11).

Flow limitation can not be used in a parallel connected district heating substation or a two-step system without a hot water priority function. In this case, the flow limitation is controlled across the two control valves in parallel.

When the priority function is active, the maximum flow limitation has to be set according to the maximum flow rate needed in the zone with the highest capacity (the domestic hot water zone or the room heating zone).

Flow limitation can only be chosen in systems where the resistance between the impulse tube connections is well defined. As a result it will not be recommended in a directly connected system as the entire resistances (radiator valves) normally are not well defined.

Flow limitation will normally not be selected if it is used as tariff allocation because a part of it, (the motorized control valve) is owned by the consumer. Consequently, the district heating utility has no influence on this part of the flow limitation system.

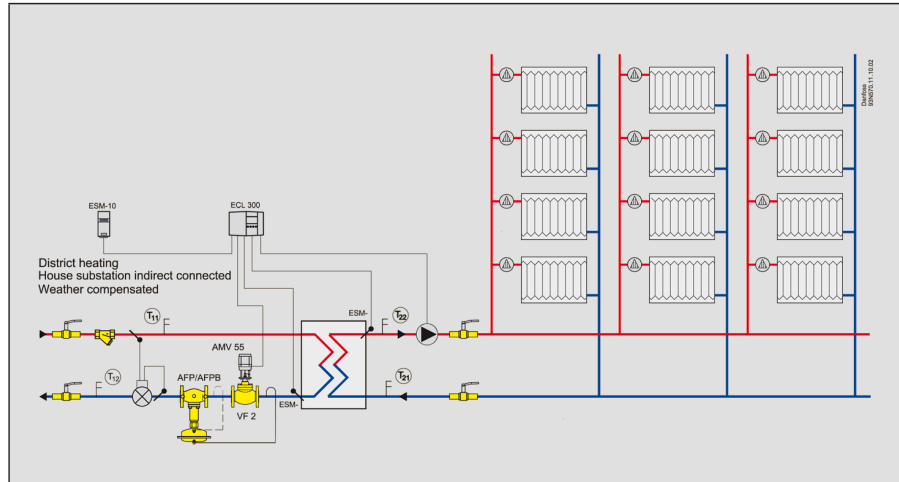

FIGURE 8: Combined differential pressure and flow limiter in a room heating system

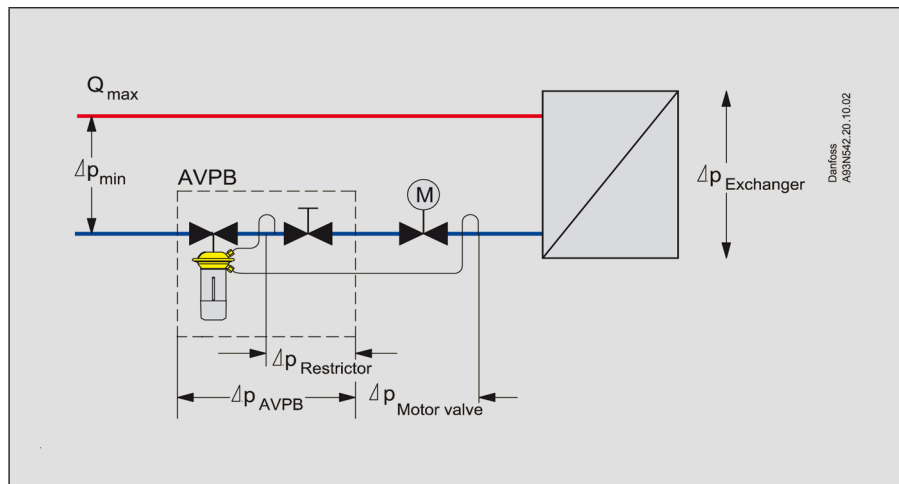

FIGURE 9: The Δp controller maintains a constant Δp across the motorized valve and the Δp controller restriction valve. The flow limitation is set on the Δp controller

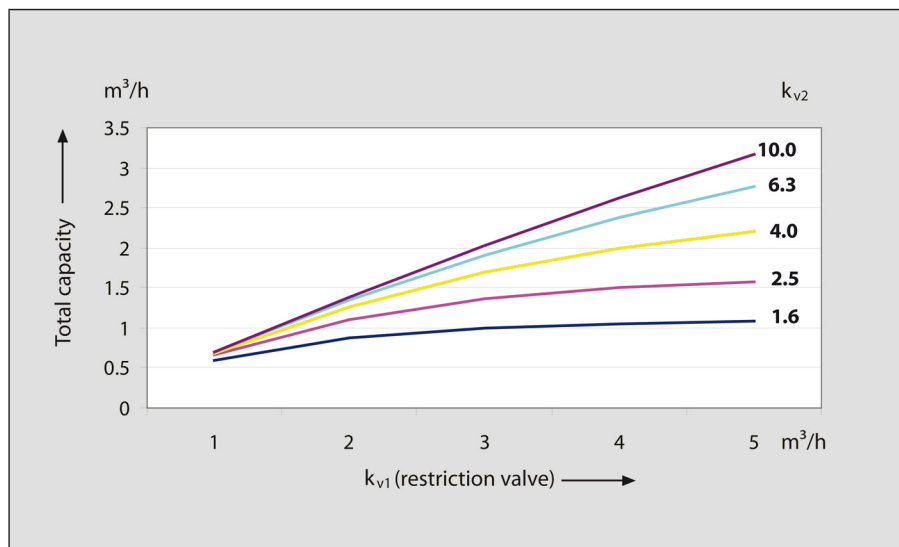

FIGURE 10: Total capacity of a system with combination of two serial connected valves ($\Delta p_{\text{set}} = 0.5 \text{ bar}$)

Combined Differential Pressure Controller and Flow Controller

A combined differential pressure controller and flow controller has two diaphragm elements. The controller has a restrictor integrated in the valve in the same way as the flow limiter.

The element near to the controller controls and limits the water flow in the system independently of the differential pressure controller function.

The lower diaphragm element controls the differential pressure in a system loop.

The Δp controller maintains a constant Δp across the entire system with the lower diaphragm. The upper diaphragm is for flow control, it keeps a constant Δp across the restrictor valve of 0.2 (0.5) bar depending on the Δp across the motorized control valve (figure 11).

If a capacity control is preferred in a system with mixing loop, a combined differential pressure and flow controller is the correct solution.

Typical systems with flow control (figure 12):

- directly connected systems,
- systems where the tariff system is based on the maximum flow rate,
- systems where the maximum flow limitation is lower than the maximum capacity for the system. DHW (Domestic hot water system) priority systems.

Accuracy of the Flow Limitation

The expected accuracy of the flow limitation depends on the pressure variation in the part of the system between the points where the impulse tubes are connected.

As a differential pressure controller is a proportional controller, the pressure variation which can be seen is the change in the controller's control deviation ΔX_p during variations in the differential pressure in the supply network.

The accuracy in the flow variation ΔQ can be calculated. ΔQ at increased differential pressure in the network is:

$$\Delta Q = Q_1 - Q_2$$

$$\Delta Q = Q_1 - k_v \cdot \sqrt{\Delta p_{set} - \Delta X_p}$$

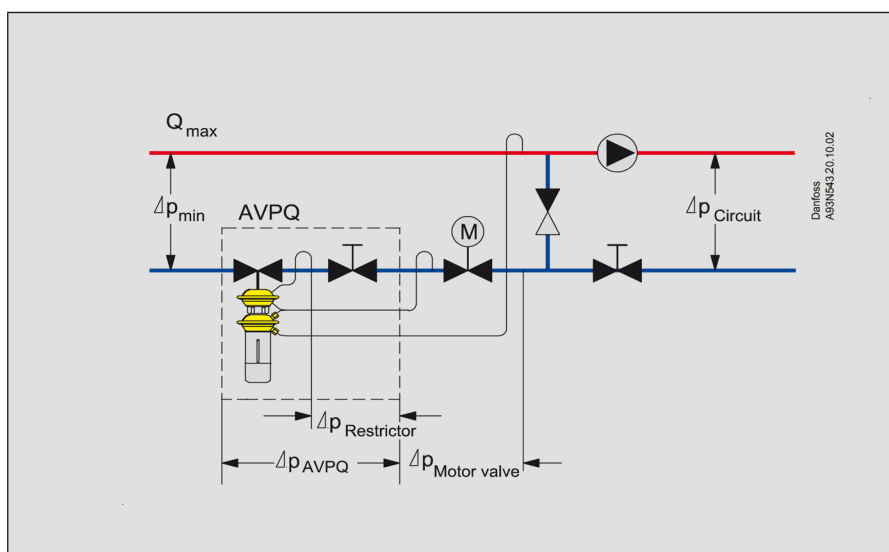

FIGURE 11: Combined differential pressure and flow control of a directly connected mixing loop system

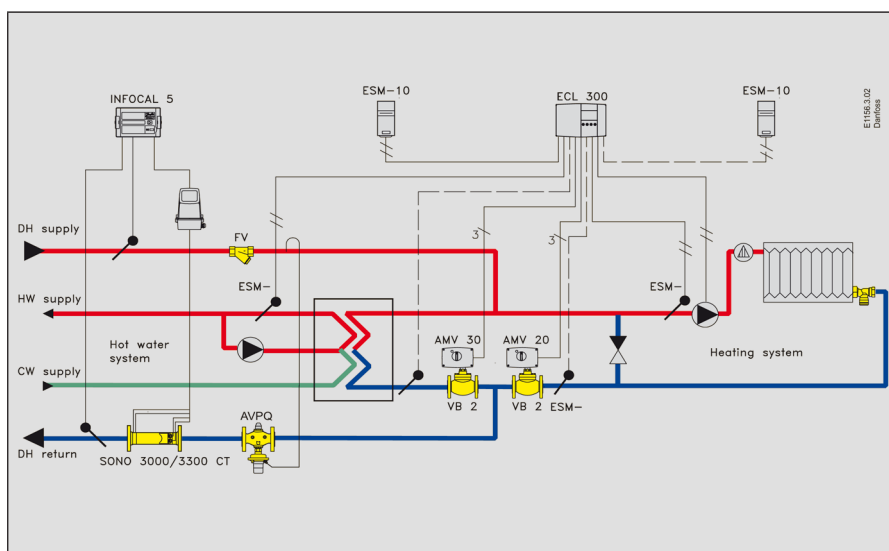

FIGURE 12: Directly connected system with combined differential pressure and flow control

with

$$k_v = \frac{Q_1}{\sqrt{\Delta p_{set}}}$$

$$\Delta Q = Q_1 - \frac{Q_1}{\sqrt{\Delta p_{set}}} \cdot \sqrt{\Delta p_{set} - \Delta X_p}$$

$$\frac{\Delta Q}{Q_1} = 1 - \frac{\sqrt{\Delta p_{set} - \Delta X_p}}{\sqrt{\Delta p_{set}}} \cdot 100\%$$

with

- ΔQ : flow variation in m^3/h ,
- Q_1 : minimum flow rate in the system in m^3/h ,
- Q_2 : maximum flow rate in the system in m^3/h ,

ΔX_p : variation in control deviation because of the proportional band in the controller in bar,
 Δp_{set} : set value of the differential pressure in bar.

Figure 13 shows the calculated accuracy of the flow limitation if a differential pressure controller is used as flow limiter. The accuracy is higher at the increased controlled differential pressure Δp_{set} .

Operating with lower X_p can increase the accuracy of the flow limitation. However, the lower X_p , the larger the dimensions of differential pressure

controllers. Therefore, it has to be taken into consideration that the lower the X_p , the higher the risk of oscillation in the differential pressure controller.

Combination Valve

Besides the room heating circuit, the substation often have more circuits connected. Typically, additional circuits are domestic hot water supply and air conditioning.

If a common differential pressure controller is chosen to control the differential pressure for the entire system, the setting of the pressure on the controller has to correspond to the highest differential pressure needed in the individual circuits. This means that the other circuits will have a higher differential pressure than required. Consequently, the total flow rate in the system will be higher than needed, unless a priority system is chosen.

In this case combination valves with integrated flow control and a motorized control valve in each circuit will be a good solution (figure 14).

Summary

Establishing a hydraulic balance in a system often is a matter of controlling the differential pressure to a level necessary for operating the substation and thereby also controlling the flow rate in individual branches. Controlling differential pressure and flow rate in the system can have advantages for customers and utilities. Advantages for the customers are:

- well defined specification for valve sizing,
- simple adjustment of the substation,
- stabilization of the temperature control,
- low noise level in the system,
- prolonged life-time of the control equipment.

Advantages for the utilities are:

- well and fair distribution of water flow rate in the supply network,
- delimitation of the circulated water quantity in the network and thereby achieving a low return temperature in the network.

Among others, this will in the future bring hydraulic balance in district heating systems into focus in the continuous effort to reduce the running costs.

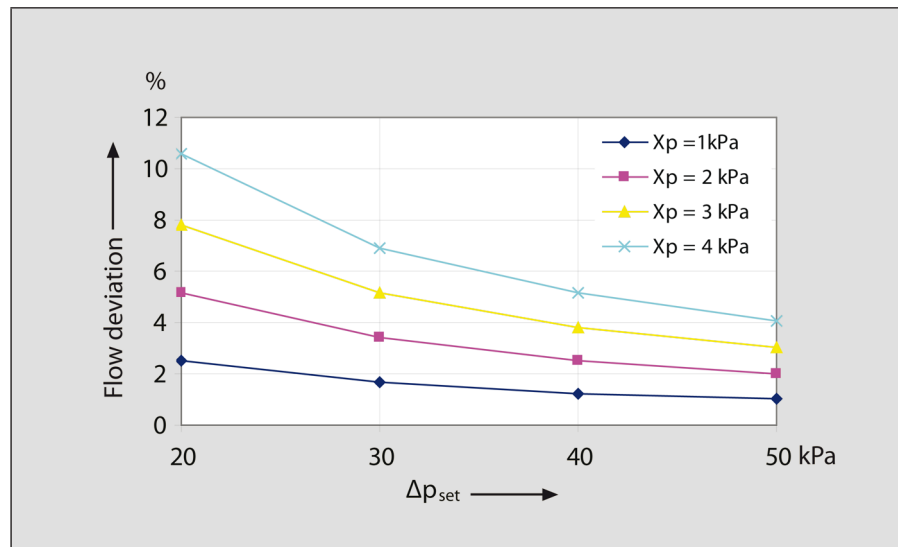

FIGURE 13: Calculated accuracy of the flow limitation if a differential pressure controller is used as flow limiter. The accuracy is higher at the increased differential pressure Δp_{set}

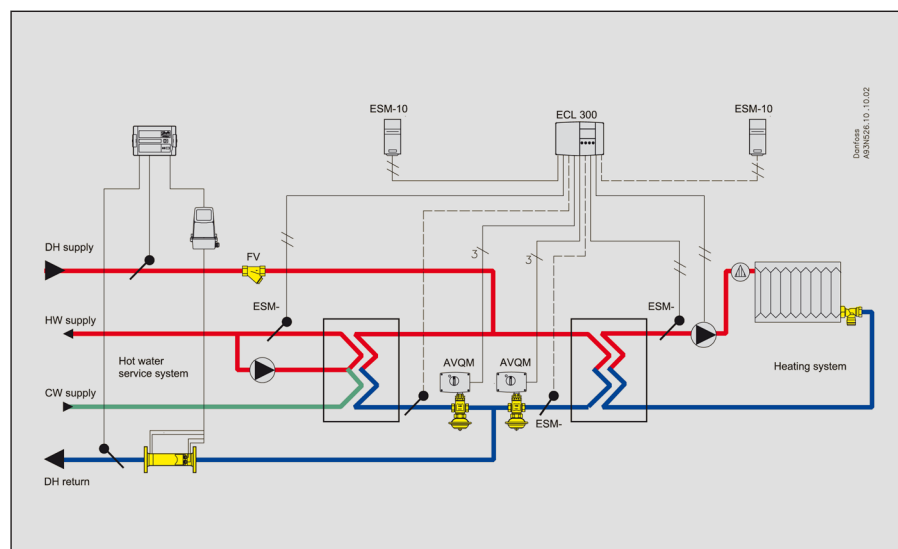

FIGURE 14: House station with room heating and domestic hot water zone supplied with combination valves

References

[1] Thorsen, J.E.; Boysen, H.: *How to avoid pressure oscillations in district heating systems*
Published in EuroHeat&Power English edition II/2003.

More articles

- [1] *Valve characteristics for motorized valves in district heating substations*
by Atli Benonysson and Herman Boysen
- [2] *District heating house substations and selection of regulating valves*
by Herman Boysen
- [3] *Optimum control of heat exchangers* by Atli Benonysson and Herman Boysen
- [4] *Auto tuning and motor protection as part of the pre-setting procedure in a heating system* by Herman Boysen
- [5] *kv: What, Why, How, Whence?* By Herman Boysen
- [6] *Pilot controlled valve without auxiliary energy for heating and cooling system*
by Martin Hochmuth
- [7] *Pressure oscillation in district heating installation* by Bjarne Stræde
- [8] *Dynamic simulation of DH House Stations* by Jan Eric Thorsen
- [9] *Differential pressure controllers as a tool for optimization of heating systems*
by Herman Boysen

More information

Find more information on Danfoss District Energy products and applications on our homepage: **www.districtenergy.danfoss.com**

Danfoss A/S · DK-6430 Nordborg · Denmark · Tel.: +45 74 88 22 22 · Fax: +45 74 49 03 95

E-mail: districtenergy@danfoss.com · www.districtenergy.danfoss.com

Danfoss can accept no responsibility for possible errors in catalogues, brochures and other printed material. Danfoss reserves the right to alter its products without notice. This also applies to products already on order provided that such alterations can be made without subsequential changes being necessary in specifications already agreed. All trademarks in this material are property of the respective companies. Danfoss and the Danfoss logotype are trademarks of Danfoss A/S. All rights reserved.